

ROTARY CAPPER

CVC 3074-8



The compact-designed CVC 3074-8 rotary capping system provides the great performance and stability to satisfy the modern bulk production.

CVC Rotary Servo Capping Systems are available for the following types of capping applications:

- Plastic Screw-on caps
- Snap-on caps
- Push-in stoppers, and plugs

STANDARD FEATURES

- Production Output is up to 200 bottles per min. (Actual output will be depending on customer's containers and caps. Our factory evaluation is required.)
- 8 Servo Driven Capping Heads
- Table top design features ease of machine cleanup and operator's access
- Stainless steel construction, meeting GMP regulations
- Servo motor driven system is applied for consistent torque application
- Siemens PLC and 12.1" Touch Screen Panel PC-based HMI
- Up to 500 Recipes which allow operator to perform quick storage and recall of capping job memory
- Main Drive System is servo motor driven
- Capping head up/down and rotation are individually driven by advanced Linmot liner motors, which feature precise capping control and ease of adapting to a wide range of capping applications
- Capping torque inspection system
- CE standard PC safety guard
- Type 304 stainless steel bin, frame, cap disc and enclosure panels
- ISO 9001 : 2015 certified



CVC 3074-8 Technical Specifications

Max. Productivity (subject to trial confirmation)	Up to 200 Bottles per Minute (BPM) based on 100ml round bottle
Applicable Product	Bottles shape: round and square bottles, irregular shaped bottle (*) Cap types: Screw caps, Press-on caps (**)
Applicable Size	Bottle Dia.: Ø30~70mm (1 1/4" to 2 3/4") Bottle Height: 65~220mm (2 5/8" to 8 1/4") Cap Dia.: Ø30~60mm (1 1/4" to 2 1/4") Cap Height: 8~22mm (11/32" to 27/32")
Power Supply	380 V/ 50(60) HZ/ 3 PH
Power Consumption	10,000 VA (16 A)
Air Pressure	6 kgf/cm ² (87psi)
Air Consumption	1,947 L/min (68.8 CFM)
Machine Dimension (L x W x H)	3,500mm x 1,690mm x 2,252mm (11'-6" x 5'-7" x 7'-5") (Including conveyor)
Machine Weight	2,223 Kg (4,900 Lbs)
Noise Level	70~75 db

* For irregular shaped bottles, please consult with CVC Engineering team.

** For press-on caps, please consult with CVC Engineering team.

TECHNICAL SPECIFICATIONS

Low maintenance cost and time:

With the use of servo main drive system, the CVC rotary capper requires only minimal maintenance.

AVAILABLE OPTIONS

- 21CFR Part 11 compliance
- OPC UA for data collection
- Cap Prefeeder (Cap Stock Elevator/ Hopper)
- Fallen bottle detection
- Bottle & cap detection system is used for foil liner and crooked caps detection
- Rejection system is in conjunction with verification devices to removing unqualified containers: cocked caps, missing foil liners, low capping torque level (if capping torque is lower than set torque)
- Rejection verification check
- Bottle format changeover parts
- Cap format changeover parts
- Cap contact parts: type 316 stainless steel



• Capping Turret

MACHINE LAYOUTS

Top View

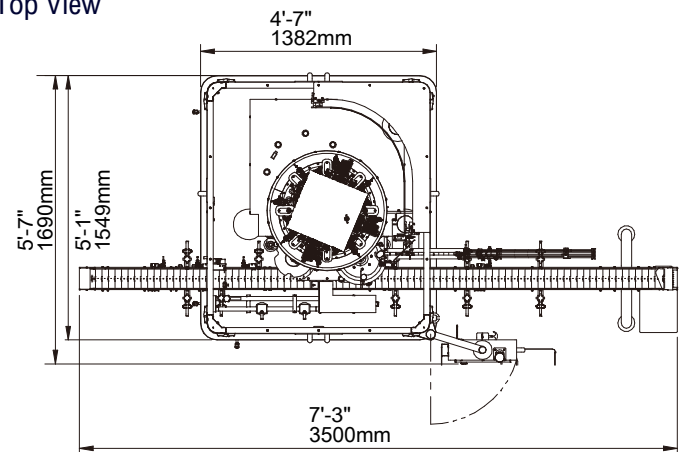

Front View

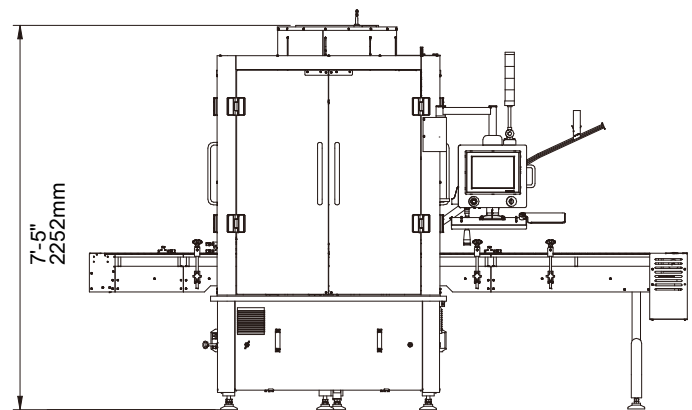

The dimensions shown are for standard machine. The conveyor can be extended: the length may vary based on selected options. This machine can run independently or be integrated into an automated packaging line. All CVC equipment is covered by a one-year parts warranty. Full Warranty details are included in our equipment proposals or can be found on our website.



Contact Us

USA

10861 Business Drive, Fontana, CA 92337
Phone: +1 (909) 355-0311
www.cvctechnologies.com
sales@cvcusa.com

USA East Coast Office

1855 New Highway, Suite C, Farmingdale NY 11735
sales@cvcusa.com

Taiwan-Asia Pacific Headquarters

Phone: +886 (4) 2496-3666
sales@cvctechnologies.com

China/ India

sales@cvctechnologies.com